



Utica Boilers MAC-205 - Submittal



Engineer: _____

Project Name: _____

Project Location: _____

Contractor: _____

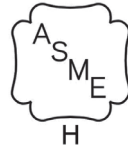

APPLICATION:

Modulating Gas fired Combi boiler for indoor installation. Approved for closet or alcove installations. For use with natural or liquefied petroleum (LP/Propane) fuel gases. Wall mounted – optional floor stand available. All boilers are factory assembled with controls and wiring and test fired to ensure dependable performance. Boiler shall be certified for Direct Vent applications only.

CERTIFICATION AND APPROVALS:

Stainless Steel heat exchanger is manufactured and tested in accordance with American Society of Mechanical Engineers (ASME) and certified by Canadian Standards Association (CSA), AHRI, NRCAN. Registered with National Board BPVI, and Massachusetts Board. Stainless steel heat exchanger is tested for maximum allowable working pressure of 50 psig in accordance with ASME boiler and pressure vessel code, section IV, rules for construction of heating boilers. A 30 psig safety relief valve is shipped standard.

BOILERS INCLUDE:

- Wall mount bracket, mounting hardware and actual size Wall Mount Template
- Boiler is equipped with internal stainless steel brazed plate heat exchanger for potable hot water and automatic 3 way diverting valve to allow Domestic Hot Water Priority operation.
- Boiler includes factory installed and wired 2 speed, electronically controlled, step modulating circulator pump. The circulator RPM is determined by the boiler temperature and controlled by the integrated boiler control.
- External Primary/Secondary manifold with quick connections shipped with boiler.
- Digital Boiler Control:
 - ▶ Upon commissioning the boiler control shall automatically recognize fuel type (natural or LP gas) and automatically calibrate for correct fuel/air mixture, optimum combustion and performance. Control continuously monitors flame signal and adjusts the gas valve during normal operation for maximum efficiency.



Manufactured by:
ECR International Inc.
2201 Dwyer Avenue, Utica, NY 13501
Tel. 800 325 5479
www.ecrinternational.com
PN 24001233 REV. D [01/31/2021]



- ▶ Control system is PCB integral controller with LCD digital/graphical display.
 - ▶ Control senses supply water temperature and adjusts the boiler firing rate to deliver the amount of heat needed and optimize efficiency.
 - ▶ Control can sense and display supply water temperature and indicate when boiler is in central heating or domestic water mode.
 - ▶ Control has selectable DHW preheat mode. Preheat mode will maintain brazed plate heat exchanger temperature to speed DHW delivery.
 - ▶ Control can accept an optional proprietary Outdoor Air sensor and has field adjustable reset curves.
 - ▶ Control displays Error Codes and Diagnostic information.
 - ▶ Control can accept 0-10V input to manage heating set-point or heating power level.
- Boiler Combustion System:
 - ▶ The Gas valve is a modulating valve capable of firing from:
 - 205,000 BTU input down to 29,500 BTU input in Combi mode (7:1 turn down).
 - 164,000 BTU input down to 29,500 BTU input in Heat mode (5.5:1 turn down).
 - ▶ Induced draft blower is variable speed controlled by the PCB.
 - ▶ Burner is constructed of Iron-Chromium stainless steel.
 - ▶ Ignition system shall incorporate a Direct Spark Igniter and a separate Flame Sensing rod.
- Heat Exchanger:
 - ▶ Boiler's primary heat exchanger is constructed of Iron-Chromium stainless steel.
 - ▶ DHW brazed plate is constructed of Stainless Steel.
- Electrical
 - ▶ 120 volts AC, 60 Hertz, 1-phase; less than 12 amps (15 amp circuit manufacturer recommended).
 - ▶ Factory wired 3-foot appliance cord with male plug end.
 - ▶ Low voltage terminal strip for Thermostat, and Outdoor Air Sensor.
- Other:
 - ▶ Field supplied Anti-Scald valve is required for Domestic Hot Water Supply.
- Warranty
 - ▶ Factory Standard Limited Warranty is 10 years on heat exchanger, one year on parts.
 - ▶ Please see the Limited Warranty for More Detail on Warranty Registrations & Extensions.
- Optional Equipment
 - ▶ Outdoor Air Sensor Kit
 - ▶ Coaxial and Two-pipe venting components
 - ▶ Floor Stand Kit



Clearances		Combustible Materials (Required) ⁽¹⁾		Service ⁽¹⁾⁽²⁾	
⁽¹⁾ Required distances measured from boiler jacket. ⁽²⁾ Service, proper operation clearance recommendation. *Allowance for piping at bottom of boiler not included.	Top	0"	0 mm	8-5/8"	220 mm
	Left Side	1-3/4"	45 mm	1-3/4"	45 mm
	Right Side	1-3/4"	46 mm	1-3/4"	45 mm
	Front	0"	0 mm	17-3/4"	450 mm
	Back	0"	0 mm	0"	0 mm
	Bottom	0"	0 mm	9-13/16"	250 mm
	Combustion Air / Venting Piping	0"	0 mm	6"	155 mm
205 Physical Data & Specifications					
Central Heat Supply & Return		1" NPT - Male			
Central Heat Primary / Secondary Manifold		1-1/4" Copper Sweat			
DHW (Cold Water) Inlet & Outlet		1" NPT - Male			
Gas Connection		3/4" NPT - Female			
DHW Maximum Flow Rate		5.0 GPM			
Dimensions / Weights		"Width"	"Height"	"Depth"	"Weight"
		17-3/4"	30"	21-1/2"	168 lbs.
Electrical		120 Volts AC, 60 Hertz, Single Phase, less than 12 amps (15 amp circuit recommended)			

Size	Input Rate (MBH) 0-2000 ft	Heating Capacity (MBH) 0-2000 ft	Net AHRI Rating, Water (MBH) 0-200 0ft	Vent Diameter O.D. Coaxial	Vent Diameter 2-pipe	AFUE (%)
Heating Mode	164,000	153,000	133,000	4" / 2" 100mm/60mm	2" or 3"	95.0
DHW Mode	205,000	184,500	N/A	4" / 2" 100mm/60mm	2" or 3"	N/A



Central Heating (Sealed System)	
Max System Pressure	43.00 psi / 2.96 bar
Min System Pressure	7.25 psi / 0.50 bar
Max System Temperature	176°F / 80°C
Pressure Relief Valve Setting	30.00 psi / 2.11 bar
Flow Connection	1" NPT
Return Connection	1" NPT
Relief Valve Connection	3/4" NPT
Recommended Operational System Pressure	21.7 psi / 1.5 bar

Domestic Hot Water (Sealed System)	
Max Inlet Pressure	116.00 psi / 8 bar
Min Inlet Pressure	2.9 psi / 0.2 bar
Min DHW Flow Rate	0.55 gpm / 2.50 l/min
Cold Water Inlet Connection	3/4" NPT
DHW Outlet Connection	3/4" NPT
Max DHW Temperature	140°F/60°C
DHW Water Content	0.10 gal/ 0.37 L



Manufactured by:
ECR International Inc.
2201 Dwyer Avenue, Utica, NY 13501
Tel. 800 325 5479
www.ecrinternational.com
PN 24001233 REV. D [01/31/2021]

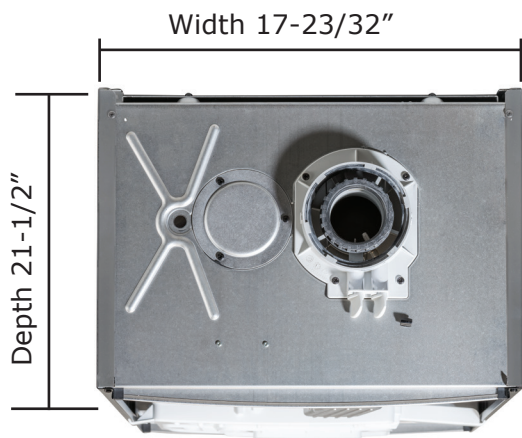

View - Front of Boiler

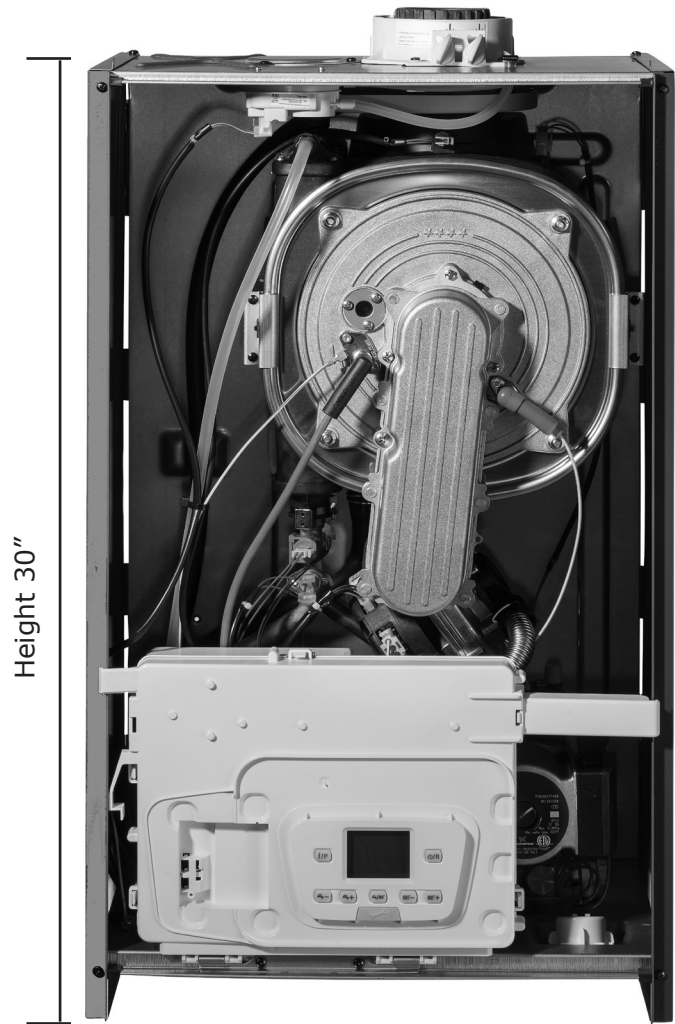

Venting

Coaxial Venting

Connects directly to the top of the boiler



2-Pipe Venting - Optional Kit

Using polypropylene - 80 mm venting



2-Pipe Venting - Optional Kit

Using CPVC UL1738/S626 - 3" venting



Total Vent Equivalent Lengths* - Account For Fittings As Listed					
	Coaxial	Twin Pipe			CPVC UL1738/ S636
		Rigid		Flexible	
Vent Size	4"/2" [100/60]	3" [80 mm]	2" ** [60 mm]	3" [80 mm]	3" [80 mm]
Total Maximum	32.8 ft [10 m]				
Air Intake Maximum		49 ft [15 m]	85 ft [25.9 m]	50 ft [15.2 m]	49 ft [15 m]
Intake + Exhaust		196.8 ft [60 m]	170 ft [51.8 m]	130 ft [40 m]	196.8 ft [60 m]
90° elbows	3.28 ft [1.0 m]	1.64ft [0.50 m]	3 ft [0.91 m]	1.64ft [0.50 m]	1.64 ft [0.50 m]
45° elbows	1.64 ft [0.50 m]	0.82 ft [0.25 m]	5 ft [1.5 m]	0.82 ft [0.25m]	0.82 ft [0.25 m]

* Refer to IOM for complete venting details.
 ** Use venting manufacturer's components to transition from 3" [80 mm] to 2" [60 mm]

ECR international

2201 Dwyer Avenue, Utica, NY 13501

Tel. 800 325 5479

www.ecrinternational.com

All specifications subject to change without notice.

©2021 ECR International, Inc.